

AKÜLÜ TRANSPALET

Electric Walkie Pallet Truck



- The Mini type with same size as hand pallet truck widely used in narrow aisle workshop, supermarket & cargo containers.

ADVANTAGE:

- Adopting floating balance wheel can prevent the side swing of the truck when traveling.
- Travel smoothly and no swing; great anti-vibration.
- The whole balance wheel can be removed, easy to maintain.
- The rocker arm mechanism integral structure which improves the structure strength effectively, meanwhile, share and adjust the even force from the fork. Reduce the obvious deflection in fork height after a long use and when loading.
- The drive wheel adopts horizontal type structure which makes the layout position of the motor higher off the ground to prevent the water, dust and greasy dirt gluing on the motor effectively and improve working condition of the motor. The truck is equipped with a height limit switch.

DIMENSION DRAWING:

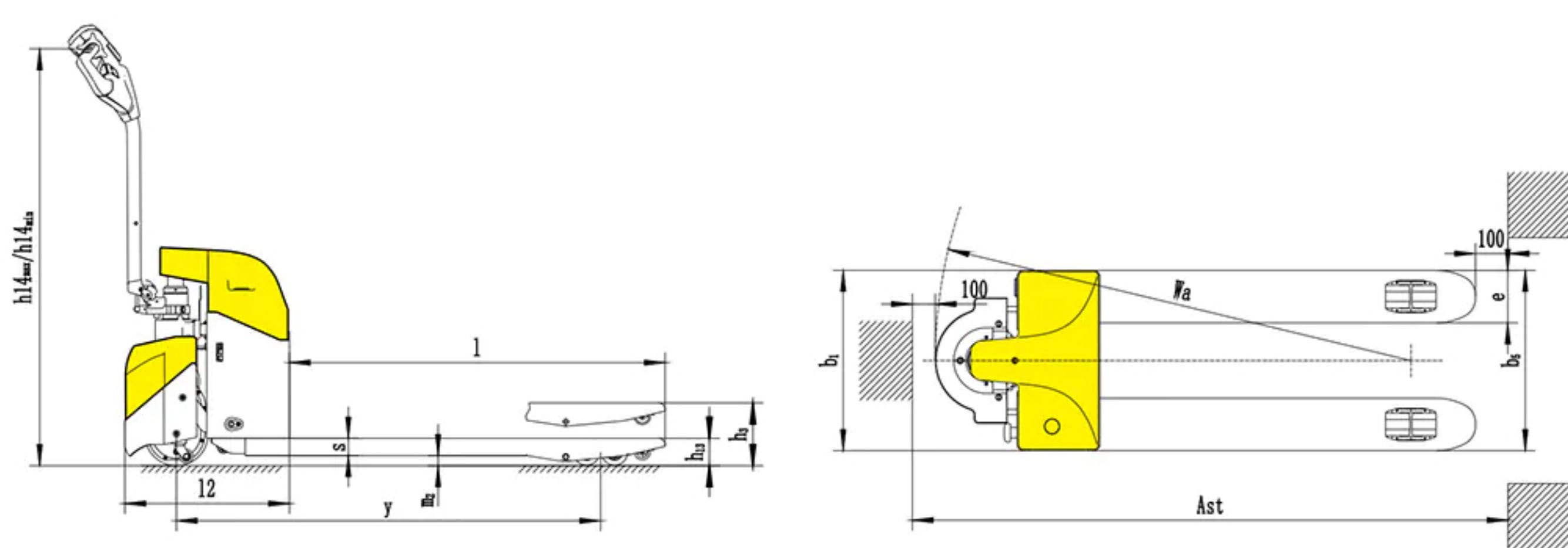

Model

Drive: electric (battery type, mains, ...), diesel, petrol, fuel gas		Electric	Electric
Operator type: hand, pedestrian, standing, seated, order-picker		Pedestrian	Pedestrian
Rated capacity/rated load	Q(kg)	1500	2000
Load centre distance	c(mm)	600	600
Load distance, centre of drive axle to fork	x(mm)	951/1021	935/1005
Wheelbase	y(mm)	1287/1357	1283/1353
Service weight		205	220
Axle loading, laden front/rear		505/1200	600/1620
Axle loading, unladen front/rear		165/40	170/50
Tyres: solid rubber, super elastic, pneumatic, polyurethane		Polyurethane (PU)	Polyurethane (PU)
Tyre size, front		Φ195x70	Φ195x70
Tyre size, rear		single Φ80x93/74x93 tandem Φ80x70/74x70	single Φ80x93/74x93 tandem Φ80x70/74x70
Additional wheels (dimensions)		44x17	44x17
Wheels, number front/rear (x = driven wheels)		1X+2/2(4)	1X+2/2(4)
Tread, front	b10(mm)	284	284
Tread, rear	b11(mm)	360/390/525	360/390/525
Max. lift height	h3(mm)	110	110
Height drawbar in driving position min./max	h14(mm)	700/1250	700/1250
Height lowered	h13(mm)	85/75	85/75
Overall length	l1(mm)	1654/1724	1654/1724
Length to face of forks	l2(mm)	504	504
Overall width	b1/b2(mm)	685/562	685/562
Fork dimensions DIN ISO 2331	s/e/l(mm)	53/160/1150(1220)	53/160/1150(1220)
Fork spread	b5(mm)	520/550/685	520/550/685
Ground clearance, centre of wheelbase	m2(mm)	32/22	32/22
Aisle width for pallets 1000 x 1200 crossways	Ast(mm)	2260/2328	2244/2310
Aisle width for pallets 800 x 1200 lengthways	Ast(mm)	2128/2365	2120/2155
Turning radius	Wa(mm)	1454/1424	1440/1510
Travel speed, laden/unladen	km/h	4.3/4.8	4.3/4.8
Lift speed, laden/unladen	m/s	0.025/0.03	0.025/0.03
Lowering speed, laden/unladen	m/s	0.035/0.025	0.035/0.025
Max. gradeability, laden/unladen	%	5/20	5/20
Service brake		Electromagnetic	Electromagnetic
Drive motor rating S2 60 min	kW	0.65	0.75
Lift motor rating at S3 15%	kW	0.8	0.8
Battery voltage/nominal capacity K5	(V)/(Ah) or kWh	24/65	24/105
Battery weight	kg	36	49
Sound pressure level at the driver's seat	dB(A)	70	70

*Option: Lithium battery 24V/50AH (charger 24V/20A)